

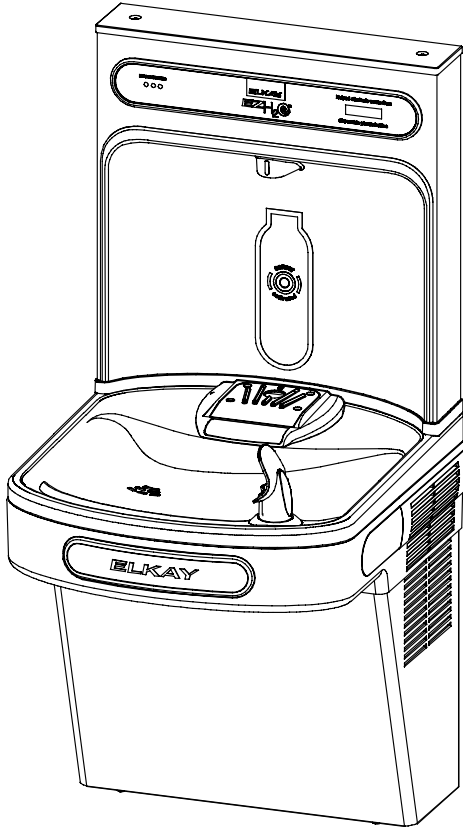

INSTALLATION, CARE & USE MANUAL

LZS8WS EZH2O™ BOTTLE FILLING STATION & COOLER



IMPORTANT

THIS IS AN INDOOR APPLICATION ONLY.
ALL SERVICE TO BE PERFORMED BY AN
AUTHORIZED SERVICE PERSON.

TOOLS REQUIRED

BUT NOT PROVIDED:

SAFETY GLASSES
GLOVES
ELECTRIC DRILL
3/4" WRENCH OR CRECENT WRENCH
5/16" NUT DRIVER
UTILITY KNIFE
TAPE MEASURE
PENCIL
CENTER PUNCH
1/2" SOCKET & RATCHET WRENCH
5/32" ALLEN WRENCH

IMPORTANT! INSTALLER PLEASE NOTE.

THE GROUNDING OF ELECTRICAL EQUIPMENT SUCH AS TELEPHONE, COMPUTERS, ETC. TO WATER LINES IS A COMMON PROCEDURE. THIS GROUNDING MAY BE IN THE BUILDING OR MAY OCCUR AWAY FROM THE BUILDING. THIS GROUNDING CAN CAUSE ELECTRICAL FEEDBACK INTO A FOUNTAIN, CREATING AN ELECTROLYSIS WHICH CAUSES A METALLIC TASTE OR AN INCREASE IN THE METAL CONTENT OF THE WATER. THIS CONDITION IS AVOIDABLE BY USING THE PROPER MATERIALS AS INDICATED. ANY DRAIN FITTINGS PROVIDED BY THE INSTALLER SHOULD BE MADE OF PLASTIC TO ELECTRICALLY ISOLATE THE FOUNTAIN FROM THE BUILDING PLUMBING SYSTEM. WE SUGGEST THAT THE BOTTLE FILLING STATION AND WATER COOLER BE PROTECTED BY A GROUND FAULT CIRCUIT INTERRUPTER (GFCI).

INSTALLER

LZS8WS Bottle Fillers are among the easiest to install on the market today. To insure you install these models easily and correctly, PLEASE READ THESE SIMPLE INSTRUCTIONS BEFORE STARTING THE INSTALLATION. CHECK YOUR INSTALLATION FOR COMPLIANCE WITH PLUMBING, ELECTRICAL, AND OTHER APPLICABLE CODES. After installation, leave these instructions with the Fountain for future reference.

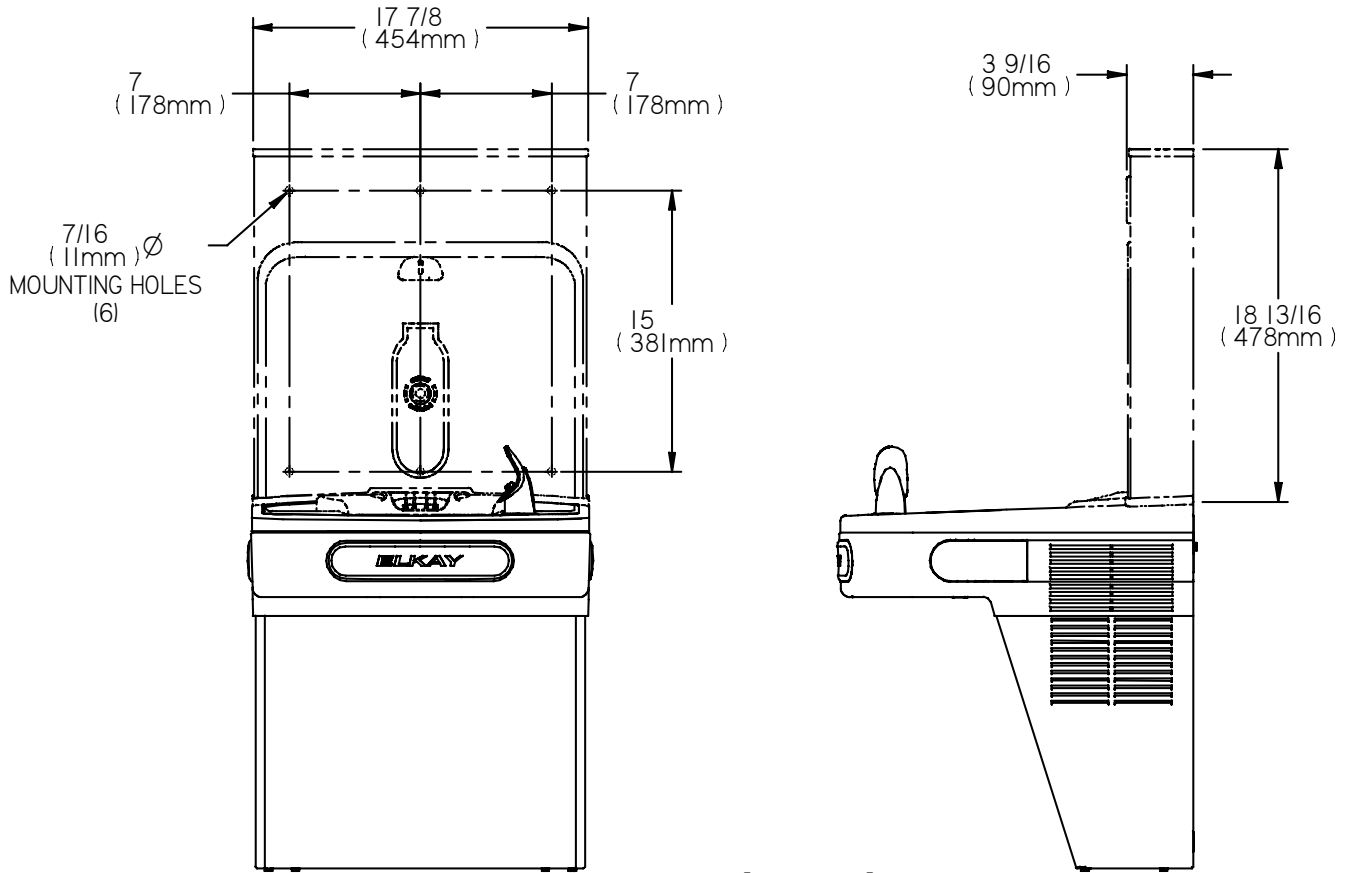

Single Rough-In
Fig. 1

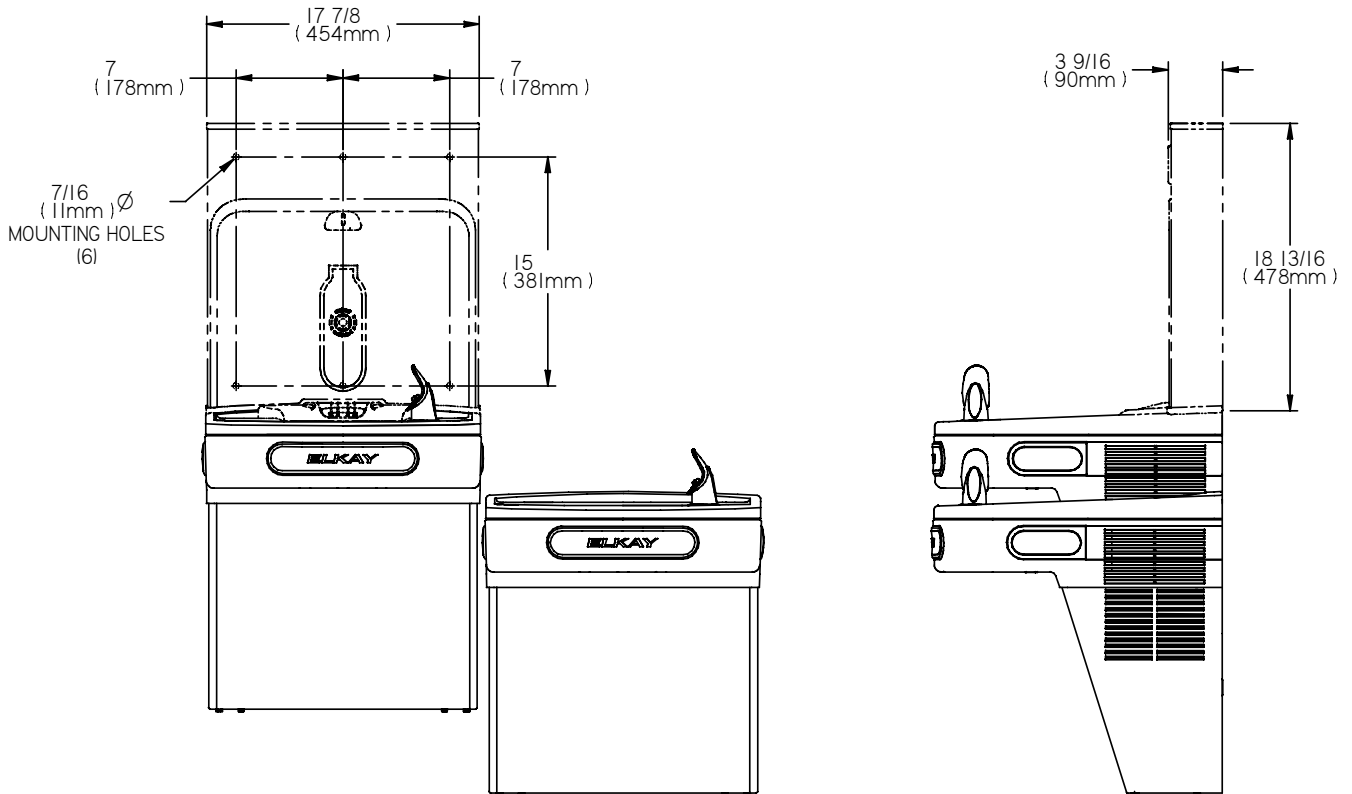

Two -Level Rough-In
Fig. 2

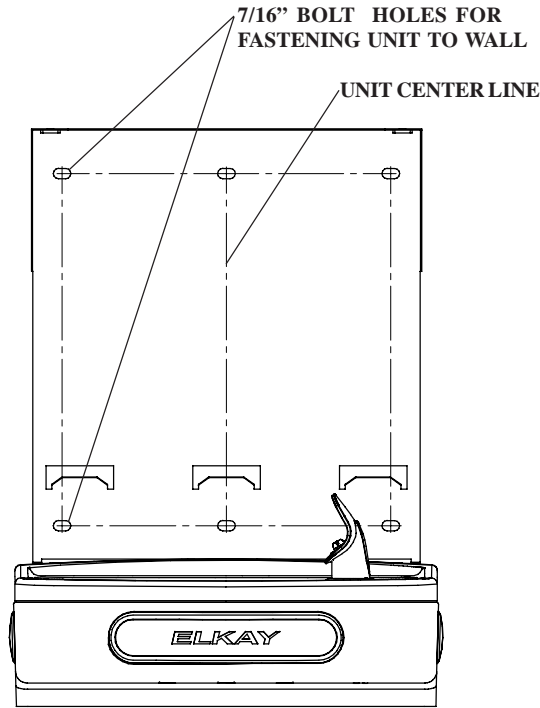

Fig. 3

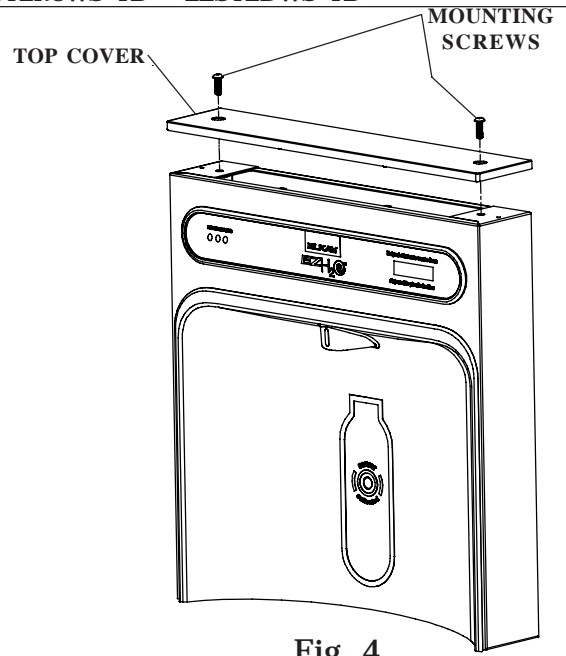
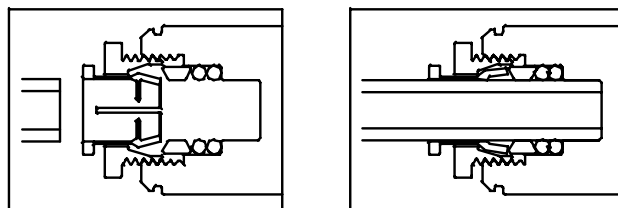

Fig. 4

BOTTLE FILLER INSTALLATION

- 1) Remove two (2) mounting screws with 5/32" allen wrench holding top cover to Bottle Filler (See FIG. 4). Remove top cover. Note do not discard mounting screws, they will be needed to reinstall top cover..
- 2) Remove wall mounting plate from Bottle Filler. Place Wall plate against wall on top of EZ basin. Center the wall plate side to side with the EZ basin. Mark the six (6) mounting holes with a pencil (See FIG. 3).
- 3) Remove wall mounting plate from wall. **NOTE:** Mounting plate **MUST** be supported securely. Add fixture support carrier if wall will not provide adequate support.
- 4) Install wall mounting plate to wall using six (6) 7/16" obround mounting holes (mounting bolts not included) (See FIG. 3). Use appropriate fasteners for your wall type.
- 5) Locate plastic bushing (provided) and place in basin hole by pushing into hole until it snaps into place. This bushing protects the water line, wire(s), and power cord from sharp edge of basin. **This part must be used.**
- 6) Place Drain Mat into position on the bottom of the Bottle Filler Unit.
- 7) Fish the purple wire (single units) or the purple and yellow wires (two-level units) up through basin hole.
- 8) **For Single Model installations:** Attach the purple wire from cooler to the purple wire on the back of the unit, (Note yellow wire is not used).
- 8a) **For Two-Level model installations:** Attach the purple and yellow wires from coolers to the purple and yellow wires on the back of the unit, purple to purple, yellow to yellow.
- 9) Remove 3/8" to 1/4" reducing union from end of waterline, (do not throw away it will be needed later). Lay Bottle Filler on water cooler basin and cut insulation from tube even with bottom of unit, remove this insulation from the 3/8" tube, but do not discard. Fish the power cord, and waterline through the hole on top of water cooler created from the "Water Cooler Preparation" section. **NOTE:** To prevent scratching the basin place a towel or soft cloth over the entire basin when working above it.
- 10) With the power cord, wire(s), and waterline through hole on top of water cooler place Bottle Filler on the three (3) angled tabs protruding from the wall mounting plate, installed on wall (See Fig. 9). Make sure rubber Drain Mat is installed properly on bottom of Bottle filler (See Cover Illustration).
- 11) Once Bottle Filler is installed on wall plate tabs, drain mat, water line, wire(s) and power cord are installed properly, push top of Bottle Filler toward wall and line up top cover two (2) holes.
- 12) Reinstall Top Cover on Bottle Filler (See FIG. 4) with two mounting screws from step 1 above. Caution do not over tighten screws.
- 13) Install remaining tube insulation to the water line from bottle filler, connect Bottle Filler waterline inside of the water cooler by connecting the 3/8" water line with the 3/8" to 1/4" union and short piece of poly tube that was previously installed to the tee.
- 14) Install filter cartridge, remove filter from carton, remove protective cap, attach filter to filter head by firmly inserting into head and rotating filter clockwise. **NOTE:** If existing plumbing roughin locations (Drain, Water In, Electric Supply) do not allow the filter to be mounted inside the cooler cabinet the filter can be installed horizontally below the unit. A retrofit kit is available to mount the filter beneath the cooler.
- 15) Turn water supply on and inspect for leaks. Fix all leaks before continuing.
- 16) Once unit has been inspected for leaks and any leaks found corrected plug Bottle Filler and EZ unit into wall. Be sure to reinstall fuse to the circuit or switch the circuit breaker back to the "ON" position.
- 17) Once power is applied to Bottle Filler, the GREEN LED light should illuminate showing good filter status along with the LCD Bottle Counter.
- 18) Verify proper dispensing by placing cup, hand, or any opaque object in front of sensor area and verify water dispenses. Note: the first initial dispenses might have air in line which may cause a sputter. This will be eliminated once all air is purged from the line.
- 19) Once unit tests out, install Lower Panel back on EZ water cooler(s). Units are now ready for use.



Note: Screw the locknut hand tight to seal

Fig. 5

OPERATION OF QUICK CONNECT FITTINGS

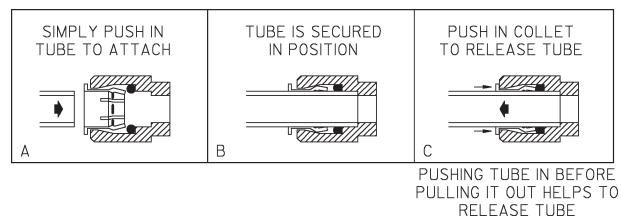

Fig. 6

CHANGING THE FILTER AND RESETTING THE VISUAL FILTER MONITOR

The electronic sensor includes LED filter status indicators that are factory preset to monitor filter life. The sensor monitors the "ON" time of the water valve solenoid and keeps track of total time water is dispensed.

There are (3) LED's that indicate the following:

Green: LED (Good) indicates that the filter is operating within 0% - 80% of its life.

Yellow: LED indicates that the filter is operating within 80% - 100% of its life.

Red: LED (Replace) indicates that the filter needs to be replaced since it has reached end of filter life.

TO CHANGE THE FILTER:

- 1) Remove the lower front panel of the watercooler by removing the four (4) screws
- 2) Turn inlet water valve off.
- 3) Open bubbler to relieve pressure build-up in the system.
- 4) Remove filter from head by rotating filter counterclockwise.
- 5) Remove new filter from carton, remove protective cap; cap may be placed on old filter to reduce the chance of water spilling from filter housing.
- 6) Attach filter to filter head by firmly inserting into head and rotating filter clockwise.
- 7) Turn on water supply and hold open the bubbler on cooler until approximately 1 gallon of water is dispensed. This flushing procedure purges air and fine carbon particles from the filter.

TO RESET THE FILTER MONITOR:

- 1) In order to reset the visual filter monitor status LED's, you must remove the top cover of the bottle filler. Remove the two (2) screws with a 5/32 allen wrench holding top cover to Bottle Filler. Remove top cover. Do not discard mounting screws, they will be needed to reinstall the top cover
- 2) With your finger, reach inside the opening and depress the program button located behind the LCD display outside of the electronics cover for approximately 2 seconds until the display changes then release. The display will change and scroll through three messages:

"RST FLTR" - Reset Filter Status LED

"RST BCNT" - Reset Bottle Count

"RNG SET" - Range Set for IR Sensor

If the program button is not pushed again the display will scroll through the three messages above for three cycles and then default back to bottle count and be back in run mode.

- 3) When the display changes to "RST FLTR", depress the button again. The display will change to show "FLT =". Depress the button again and the display will show "FLTR =0"
- 4) The Green LED should be illuminated indicating that the visual filter monitor has been reset. Reinstall the top cover.

SETTING THE CONTROL BOARD - SETTING RANGE OF THE IR SENSOR

- 1) In order to access the programming button, you must remove the top cover of the bottle filler. Remove the two (2) screws with a 5/32" allen wrench holding top cover to Bottle Filler. Remove top cover. Do not discard mounting screws, they will be needed to reinstall the top cover
- 2) With your finger, reach inside the opening and depress the program button located behind the LCD display outside of the electronics cover for approximately 2 seconds until the display changes then release. The display will change and scroll through three messages:

"RST FLTR" - Reset Filter Status LED

"RST BCNT" - Reset Bottle Count

"RNG SET" - Range Set for IR Sensor

If the program button is not pushed again the display will scroll through the three messages above for three cycles and then default back to bottle count and be back in run mode.

- 1) To set the RANGE of IR Sensor: when display shows "RNG SET" push program button once the display will show current value (can be 1 - 10) i.e. **"RNG = 3"**.
- 2) Once display shows current value push the program button to scroll through value of 1 - 10. Select the desired range setting.
- 3) Once range is selected allow approximately 4 seconds to pass and then the display will go back to bottle counter and be in run mode.
- 4) Test bottle filler by placing bottle or hand in front of sensor to make sure water is dispensed.

SETTING THE CONTROL BOARD - RESETTING BOTTLE COUNT

- 1) In order to access the programming button, you must remove the top cover of the bottle filler. Remove the two (2) screws with a 5/32 allen wrench holding top cover to Bottle Filler. Remove top cover. Do not discard mounting screws, they will be needed to reinstall the top cover
- 2) With your finger, reach inside the opening and depress the program button located behind the LCD display outside of the electronics cover for approximately 2 seconds until the display changes then release. The display will change and scroll through three messages:

"RST FLTR" - Reset Filter Status LED

"RST BCNT" - Reset Bottle Count

"RNG SET" - Range Set for IR Sensor

If the program button is not pushed again the display will scroll through the three messages above for three cycles and then default back run mode which display bottle count.

- 3) To reset the BOTTLE COUNTER: when display shows "RST BCNT" push program button once the display will show current value i.e. "BC0033183".
- 4) Once display shows current value push the program button once more to reset back to 0. The display will show BTLCT = 0 for approximately 2 seconds and then return to run mode showing 00000000 bottles.
- 5) To test bottle counter, you can place bottle or hand in front of sensor for approx 5 seconds to see bottle counter count 00000001. (This is based on filling a 16 oz bottle)

WATERSENTRY® PLUS FILTER PARTS LIST (See Fig. 7)			LISTA DE PIEZAS DEL FILTRO (Vea Fig. 7)	LISTE DES PIÈCES DU FILTRE (Voir Fig. 7)
ITEM NO.	PART NO.	DESCRIPTION	DESCRIPCIÓN	DESCRIPTION
1	51294C	Filter Head Assy.	Ensamblado de la Cabeza del Filtro	Ens. de tête de filtre
2	70792C	Screw #8-18 x .75 PH	Tornillo #8-18 x .75 PH	Vis #8-18 x .75 hp
3	70823C	Fitting - Superseal 3/8" (10mm)	Accesorio - Supersello 3/8" (10mm)	Raccord - Superseal 3/8" (10mm)
4	70822C	Fitting - Superseal 1/4" (6 mm)	Accesorio - Supersello 1/4" (6 mm)	Raccord - Superseal 1/4" (6mm)
5	51300C	Filter Assy	Ensamblado del Filtro	Ens. filtre
6	70818C	Elbow - 3/8" (10mm)	Codo - 3/8" (10 mm)	Coude - 3/8" (10mm)
7	28641C	Bracket	Fijador	Support

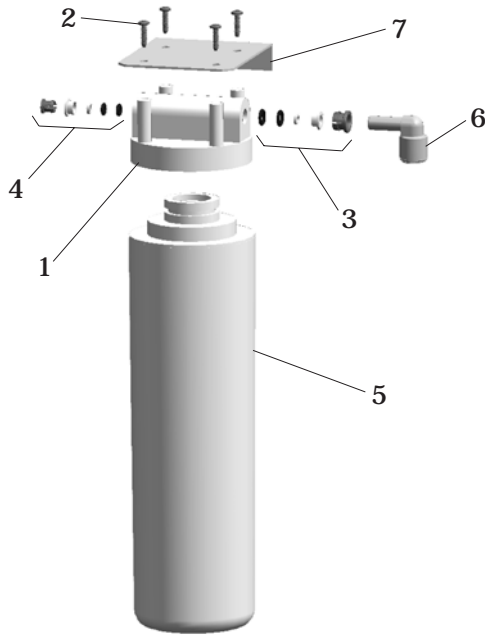

WATER FILTER EXPLODED VIEW

Fig. 7

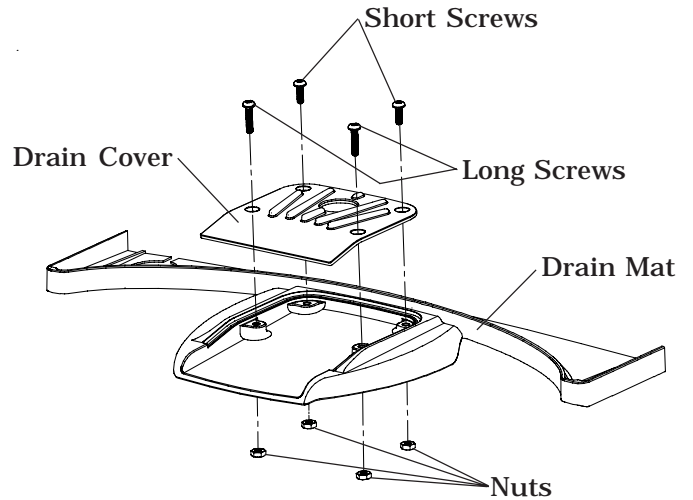

DRAIN MAT EXPLODED VIEW

Fig. 8

DRAIN MAT ASSEMBLY AND CARE

- 1) Insert a nut into each of the four hex pockets on the bottom side of mat.
- 2) Place Drain Cover on mat and install the four screws as shown in Fig. 8. Note the two shorter screw are used at the back of the cover. It is recommended that the cover be removed and the drain and drain cover be cleaned weekly. To dis-assemble or re-assemble the drain cover to the mat the mat can be picked up from the front to access the nuts beneath.

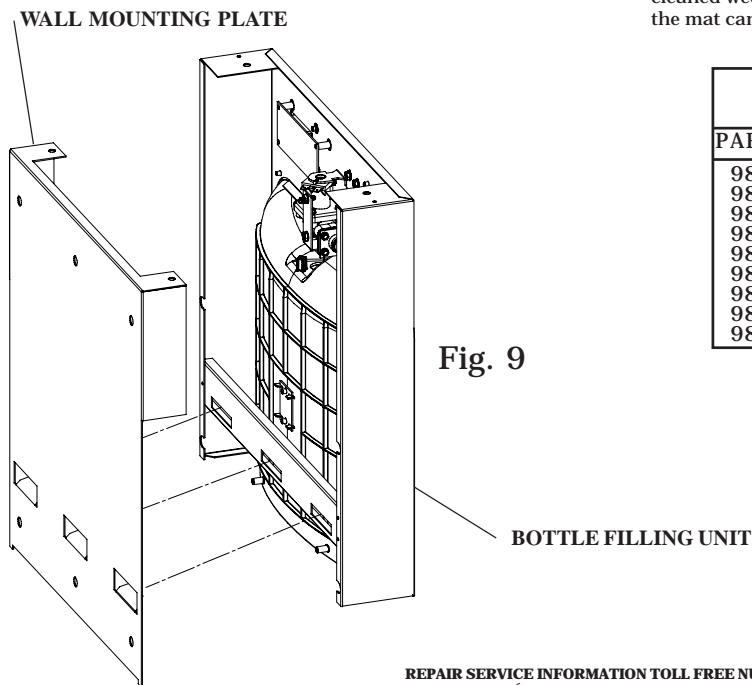

Fig. 9

REPLACEMENT PART KITS	
PART NO.	DESCRIPTION
98543C	Kit - Electrical Package
98544C	Kit - IR Sensor
98545C	Kit - Solenoid Valve Replacement
98546C	Kit - Aerator Replacement
98547C	Kit - Top Cover Replacement
98548C	Kit - Drain Mat & Cover Replacement
98549C	Kit - Hardware & Waterway Parts
98551C	Kit - Filter Mounting Cover
98552C	Kit - Retro Filter Mounting

REPAIR SERVICE INFORMATION TOLL FREE NUMBER 1.800.260.6640
 NÚMERO GRATIS DE SERVICIO 1.800.260.6640
 INFORMATIONS POUR LE SERVICE PAR NUMERO SANS FRAIS 1.800.260.6640

FOR PARTS, CONTACT YOUR LOCAL DISTRIBUTOR OR CALL 1.800.323.0620
 PARA PIEZAS, CONTACTE A SU DISTRIBUIDOR LOCAL O LLAME AL 1.800.323.0620
 POUR OBTENIR DES PIÈCES, CONTACTEZ VOTRE DISTRIBUTEUR LOCAL OU COMPOSEZ LE 1.800.323.0620

ELKAY MANUFACTURING COMPANY • 2222 CAMDEN COURT • OAK BROOK, IL 60523 • 630.574.8484

PRINTED IN U.S.A.
 IMPRESO EN LOS E.E.U.U.
 IMPRIMÉ AUX É.-U.